

PART NO.	HOLDING CAPACITY "A"	"B" ±.015 (0.4)	"C" ±.02(0.5)	"D" AT MAX CAPACITY REF.
*KKJ-2-RT	1/8 (3.2)	27/32 (21.4)	1 (25.4)	1/4 (6.4)
KKJ-3-RT	3/16 (4.8)	7/8 (22.2)	1-1/4 (31.8)	5/16 (7.9)
KKJ-4-RT	1/4 (6.4)	29/32 (23.0)	1-1/2 (38.1)	13/32 (10.3)
*KKJ-5-RT	5/16 (7.9)	1-7/32 (31.0)	1-3/4 (44.5)	7/16 (11.1)
*KKJ-6-RT	3/8 (9.5)	1-9/32 (32.5)	2 (50.8)	17/32 (13.5)

*PARTS AVAILABLE BY SPECIAL ORDER ONLY

NOTES:

1. MATERIAL: RIGID OVC (RMS-04). ALSO AVAILABLE IN CLEAR PVC (RMS-32) BY SPECIAL ORDER.
2. COLOR: GRAY.
3. TAPE: 1/16 (1.6)THICK DOUBLE SIDED ADHESIVE (RMS-150), WHITE LINER
4. CUSTOM LENGTHS AVAILABLE BY SPECIAL ORDER.
5. PARTS ALSO AVAILABLE WITHOUT THE ADHESIVE BY SPECIAL ORDER. TO ORDER REMOVE "-RT" FROM THE PART NO.

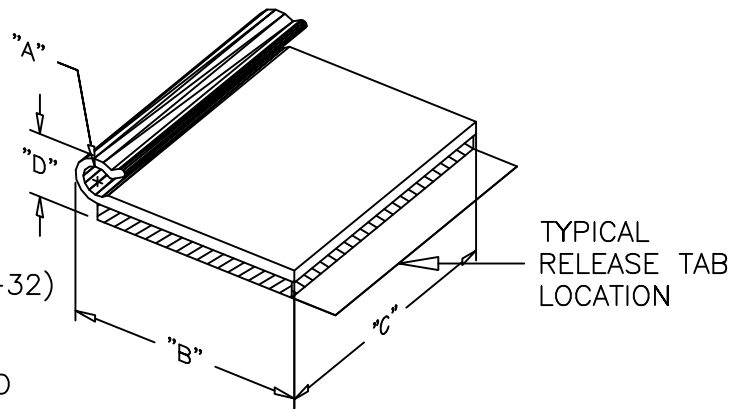

F	SEE CO 200132 FOR CHANGES	SK 02.25.08	TITLE: KWIK KLIP, TYPE "J"			DWG IN IN(MM)	
E	SEE CO 200035 FOR CHANGES	SK 09.26.07					
D	CHANGED NOTE 1 & ADDED NOTE 4	SJ .03.18.02	TOLERANCES UNLESS NOTED	FILE # KKJ	DWN: S.M.	APP:	FINAL
C	COMPLETELY RE-DRAWN & CHANGED FILE #	S.M.11.20.00	.XX=.020	MAT'L: SEE NOTE	DT: 11/20/00	DT:	PART #
B	ADDED NOTES, CORRECTED TAPE THICKNESS TO 1/16"	JK 2.10.00	.XXX=.015	RE: RICHCO, INC.	RICHCO INC.		SEE TABLE
A	TABLE CHANGED PER CATALOG VER. 25	J.L. 9.15.99	FRAC=1/64	PO BOX 804238, CHICAGO, 60680		PRINT TYPE	
REV	DESCRIPTION	ENGR DATE	ANG=1°	(773) 539-4060		CA	